

FASTEN MEMBRANE AND FLASH CURB OR WALL WITH CURED EPDM MEMBRANE FOLLOWING STANDARD PROCEDURES USING BONDING ADHESIVE VERTICALLY AND SECUR-TAPE AT MEMBRANE SPlice.

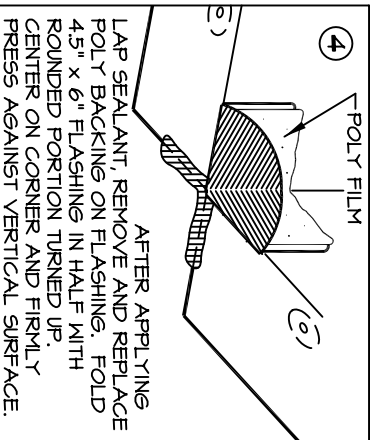

AFTER APPLYING LAP SEALANT, REMOVE AND REPLACE POLY BACKING ON FLASHING. FOLD 4.5" x 6" FLASHING IN HALF WITH ROUNDED PORTION TURNED UP. CENTER ON CORNER AND FIRMLY PRESS AGAINST VERTICAL SURFACE.

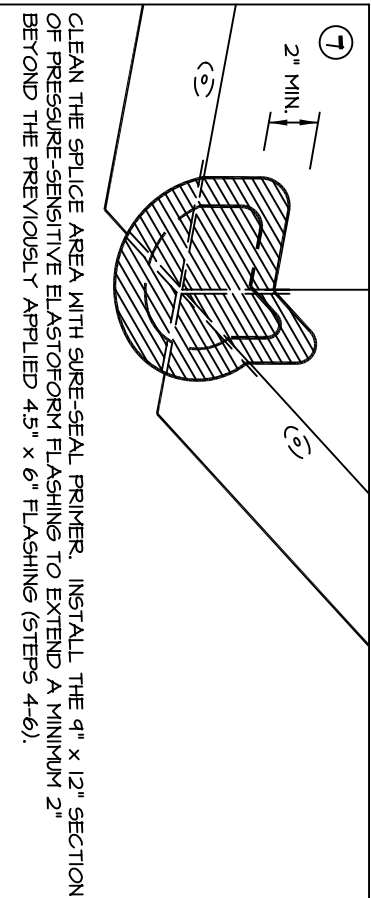

CLEAN THE SPlice AREA WITH SURE-SEAL PRIMER. INSTALL THE 9" x 12" SECTION OF PRESSURE-SENSITIVE ELASTOFoRM FLASHING TO EXTEND A MINIMUM 2" BEYOND THE PREVIOUSLY APPLIED 4.5" x 6" FLASHING (STEPS 4-6).

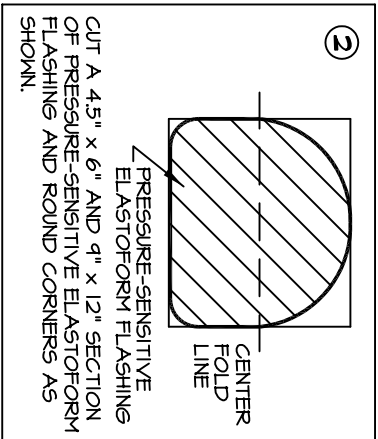

CUT A 4.5" x 6" AND 9" x 12" SECTION OF PRESSURE-SENSITIVE ELASTOFoRM FLASHING AND ROUND CORNERS AS SHOWN.

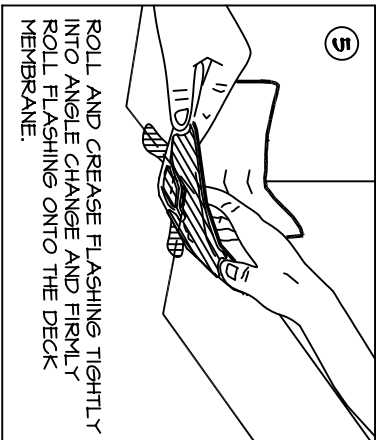

ROLL AND CREASE FLASHING TIGHTLY INTO ANGLE CHANGE AND FIRMLY ROLL FLASHING ONTO THE DECK MEMBRANE.

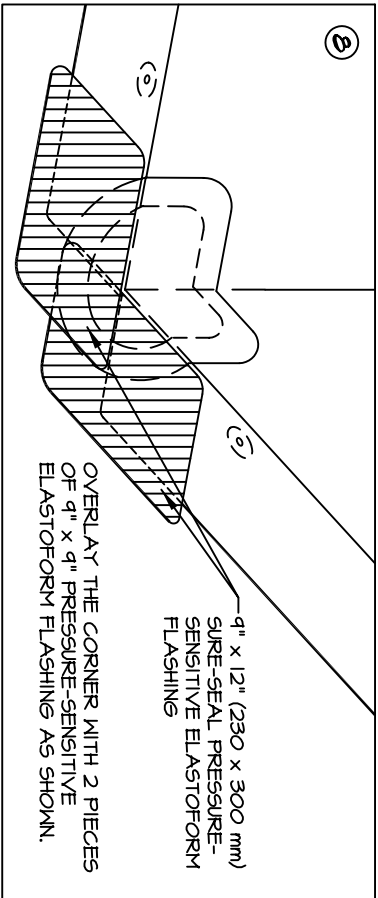

OVERLAY THE CORNER WITH 2 PICES OF 9" x 9" PRESSURE-SENSITIVE ELASTOFoRM FLASHING AS SHOWN.

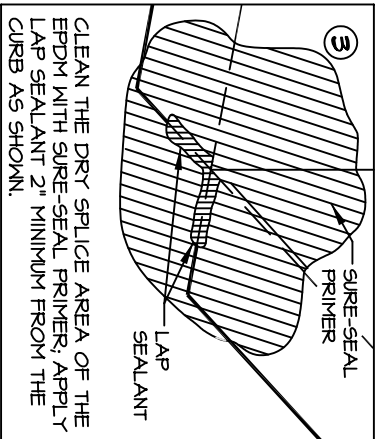

CLEAN THE DRY SPlice AREA OF THE EPDM WITH SURE-SEAL PRIMER. APPLY LAP SEALANT 2" MINIMUM FROM THE CURB AS SHOWN.

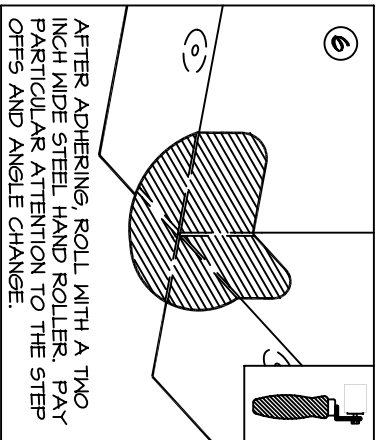

AFTER ADHERING, ROLL WITH A TWO INCH WIDE STEEL HAND ROLLER. PAY PARTICULAR ATTENTION TO THE STEP OFFS AND ANGLE CHANGE.

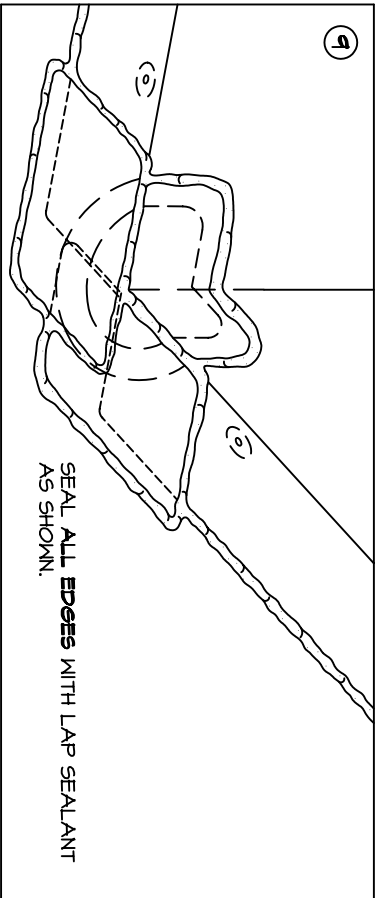

SEAL ALL EDGES WITH LAP SEALANT AS SHOWN.

30-YEAR WARRANTY

X3FEB-15C

OUTSIDE CORNER WITH PRESSURE-SENSITIVE UNCURED FLASHING

CARLISLE
Carlisle Syntec Incorporated